



Models 4.5:1 and 9:1  
Water Pump

Owner's Manual

## **WARRANTY**

Humboldt Solar Water Pump warrants each new High Lifter Water Pump against defects in materials and workmanship for one year from the date of purchase. If the pump has been installed and used according to the instructions in the owner's manual, Humboldt Solar Water Pump will either repair defects or replace the defective unit free of charge.

Humboldt Solar Water Pump assumes no further responsibility for damage that may result from improper use of the pump nor any other indirect or incidental damages. There is no warranty, expressed or implied, in case of mechanical abuse, failure to use a filter, or operation of the pump above rated pressure.



Designed and developed by  
HIGH LIFTER WATER SYSTEMS  
Willits, California  
US Patent, other patents pending  
Manufactured under exclusive agreement by

HUMBOLDT SOLAR WATER PUMP. LLC  
PO Box 1431 Ferndale, CA 95536  
(707)923-2109

[www.humboldtsolarwaterpump.com](http://www.humboldtsolarwaterpump.com)  
[info@humboldtsolarwaterpump.com](mailto:info@humboldtsolarwaterpump.com)

© 1985 and 2009

## TABLE OF CONTENTS

Introduction	1
Typical Applications	1
How the High Lifter Works	3
Principles of Operation	
Determining Pump Delivery and Performance	
The Stall Ratio	
Flow Considerations	
Installing the High Lifter	6
The Water Source and Collection Point	
The Pump Site	
The Filter	
Piping	
Air Bubbles	
Siphoning	
Maintenance and Trouble-shooting	9
Cleaning the Filter	
Disassembly	
Assembly	
The Control Valve	
High-Pressure Piston and Ratio Changeover	
Trouble-shooting Procedures	
Leakage Tests	
Collar Operation and Pilot Tests	
Valve Operation Tests	
Appendix I. Performance Curves	15
Appendix II. Trouble-shooting Flow Chart	17
Appendix III. Parts Breakdown Illustrations	18
Appendix IV. Specification Data	23

## HIGH LIFTER OWNERS MANUAL INTRODUCTION

The High Lifter water pump is an innovation in pumping technology. It is a powerful water pump that uses gravity to move water uphill without gasoline or electricity.

The High Lifter harnesses the energy from a head of flowing water, driving a portion of this water uphill. Pistons provide the pumping action and water is the only lubricant.

The High Lifter is efficient, economical, quiet, and easy to use. Though it is lightweight (the entire unit weighs less than six pounds), it is capable of extreme lifts even with low inlet flows.

This pump is ideally suited for hilly and mountainous terrain. It should be placed at an elevation at least 30 feet lower than the water source, which may be a spring, creek, or pond. The pressure of the "falling" water provides the pumping energy.

Designed to be installed and maintained by the user with basic household tools, the High Lifter requires little attention for years of hardworking service.

## TYPICAL APPLICATIONS

The High Lifter is designed to pump water for drinking and household uses, garden irrigation, range cattle, etc. In multiples of two or more, High Lifter pumps are often suitable for providing domestic water for small communities or irrigation water for agriculture.

The High Lifter pump can deliver up to 750 or 1500 gallons of water per day, depending on the model. However, the High Lifter can also be used where the flow of source water is as little as one quart per minute. The versatility of the High Lifter is demonstrated by the lifts it can achieve: from 50 to 1100 feet, depending on the circumstances.

For most domestic water systems, a tank is required to provide the necessary reservoir for constant pressure at large flows. However, in many applications, most notably drip or other irrigation systems, a tank is not needed. The High Lifter pump will reach a certain pressure level for a given system and maintain it as long as nothing changes. To obtain more pressure, you can reduce output flows or increase the fall to the pump.

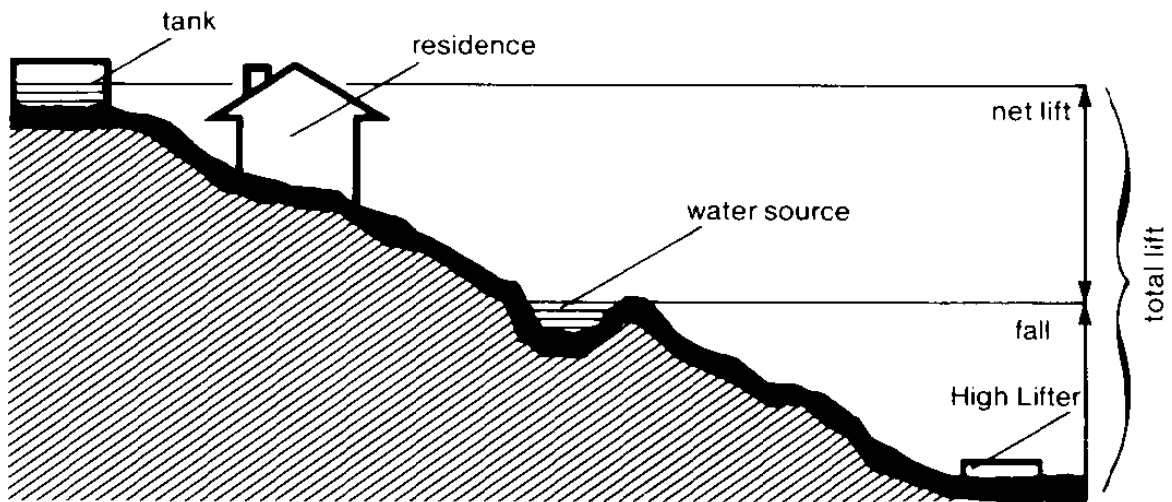

Figure 1. Typical domestic water application using tank for reservoir and for pressure to home.

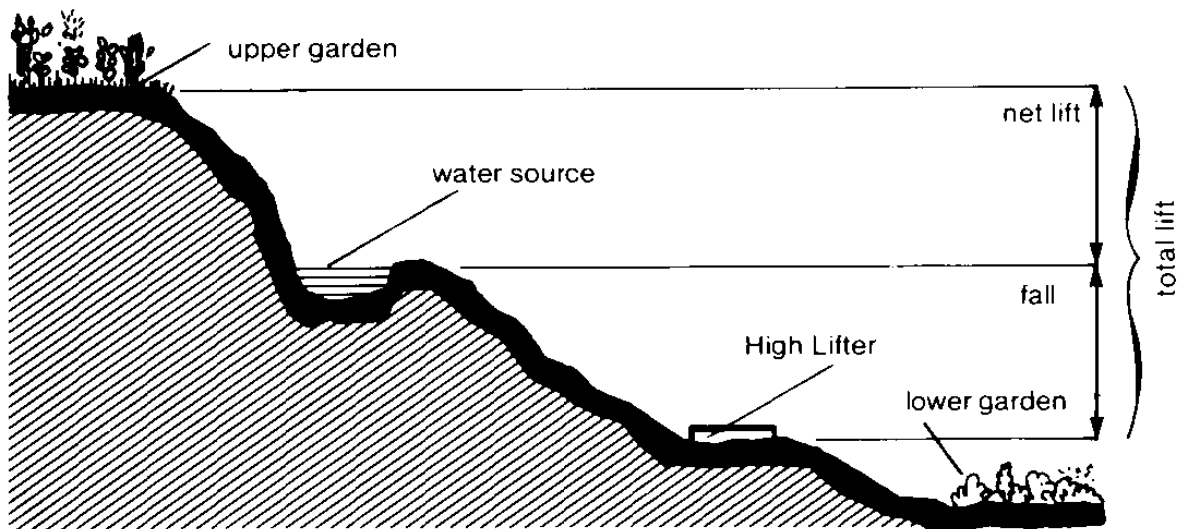

Figure 2. Typical garden/irrigation application using both pumped water and discharged water.

## HOW THE HIGH LIFTER WORKS

### PRINCIPLES OF OPERATION

The High Lifter is a positive displacement pump that uses a larger volume of low-pressure water to pump a smaller volume of water at a higher pressure. A larger piston acts with a smaller one to gain mechanical advantage, a kind of "hydraulic lever."

A collar inside the pump controls the inlet valve. As the pistons reach the end of their stroke, they contact this collar, pushing it until it directs a small amount of "pilot water" to the end of the "spool" in the valve, thereby shifting it and changing the direction of the water flow in the pump.

The flow moves the pistons in the opposite direction until they again contact the collar, which shifts the valve spool again, and the process repeats.

### DETERMINING PUMP DELIVERY AND PERFORMANCE

You can determine the amount of water the High Lifter will deliver and its performance (the number of strokes per minute) by using the performance curves at the back of this manual. This section describes how the High Lifter pumps water and explains how to use the performance curves.

The lower pressure water that flows into the High Lifter is converted by its pumping action into higher pressure water, which is pumped uphill, and into exhaust water, which is dumped out at the pump. The percentage of the source water that is pumped depends on the volumetric ratio of the pump (the ratio of the area of the large piston to the area of the small piston).

The High Lifter can be set up in two different volumetric ratios, 9:1 or 4.5:1. A 9:1 ratio pump delivers one gallon of water at the top of the hill for every nine gallons of water from the source; a 4.5:1 pump delivers a gallon for every 4.5 gallons of source water.

The volumetric ratio also determines the height that water can be lifted. The 9:1 pump lifts water up to 1100 feet; the 4.5:1 pump up to 550 feet. The High Lifter can be converted from one ratio to the other.

The number of gallons of water that the High Lifter will pump per day (or *delivery*) depends on other factors:

- The height of the source water above the pump. This is referred to as *fall*, and is measured in feet. The fall determines the *inlet pressure*, which is measured in pounds per square inch (psi).

The height that the water is pumped, from the pump itself to the point of delivery. This is called the *total lift*, and is measured in feet. The total lift determines the *output pressure*. The *net lift*, the height from the source to the delivery point, is used in the performance curves to simplify computations. (Total lift equals net lift plus fall.)

- The amount of water available at the source. This is called the *flow*, and is measured in gallons per minute).

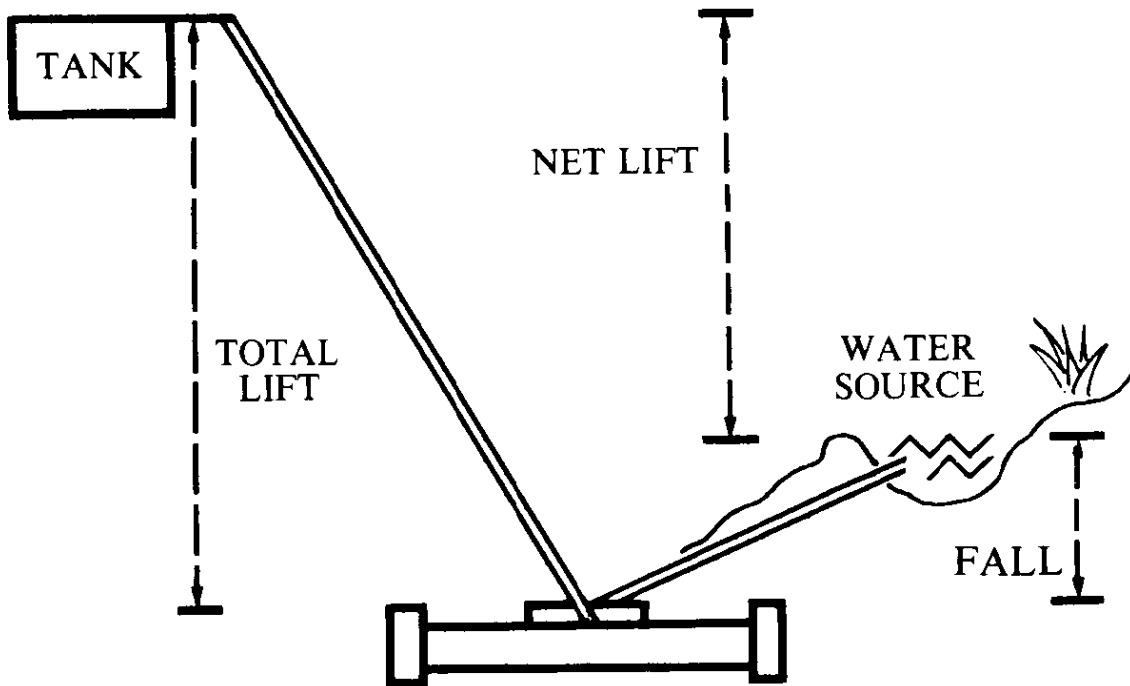

Figure 3. Net Lift and Fall

To figure out how much water the High Lifter can pump, you must know the net lift and fall. They can be determined by using topographical maps, an altimeter, a tube and water pressure gauge, a hand held sight level, a friend with a tape measure, or visual estimates. The fall must be at least fourteen feet in order for the pump to operate.

Once you know the net lift and the fall, you can find the expected delivery on the performance curves in the charts in Appendix I of this manual.

Here is an example that illustrates how to use these charts. You wish to pump water from a source to a tank 300 feet (vertical) up a hill. You may use either a 9:1 pump or a 4.5:1 pump, depending on the fall available. For a 9:1 pump, project a line horizontally from the 300-foot point on the net lift axis (at the left of the chart) until it intersects with a curve representing the fall. In this example, the first curve intersected is the 60-foot curve.

Now, to determine the amount of water that will be pumped, project a line vertically to the delivery axis at the bottom of the chart. In this example, the delivery would be almost 500 gallons per day with a fall of 60 feet. Using a 4.5:1 pump, project a horizontal line for the net lift (305 feet) until it intersects the curve representing the fall you plan to use, and then project a vertical line to determine the delivery. With a 100-foot fall, a 4.5:1 pump will deliver about the same amount of water as the 9:1 pump with a 60-foot fall. Note that using a 4.5:1 pump with the same net lift (300 feet) and

increasing the fall only slightly, for example to 120 feet, will deliver more than twice as much water, about 1100 gallons per day. The numbers at the top of the chart show the flow in gallons per minute that is required at the source in order to produce the rated delivery. If there is insufficient water at the source, the pump will "get ahead" of the flow, thus reducing the inlet pressure. The pump will then operate more slowly. A 9:1 ratio pump requires approximately three and a half gallons per minute of flow at the source to deliver 500 gallons per day of pumped water. A 4.5:1 pump needs one half as much water at the source or about one and three quarter gallons per minute to deliver the same 500 gallons per day. When you first install the High Lifter, it may not deliver as much water as the performance curves predict. However, you can expect improvement as the new seals need to wear in a bit. The biggest improvement will be in the first day, but the delivery may continue to increase for a week or more. If your High Lifter delivers more water than you can use, you can minimize needless wear and avoid over-delivery by regulating the inlet flow with the inlet filter valve. Partially closing this valve reduces the inlet pressure, causing the pump to stroke more slowly. Alternatively, a float valve can be installed at the top in the tank, but regulating the inlet flow is usually a simpler and less costly procedure.

#### THE STALL RATIO

The volumetric ratio — the ratio of the area of the large piston to that of the small piston — theoretically corresponds to the ratio of the output water pressure to inlet pressure. However, the actual ratio, called the "working ratio," is always lower because of friction. The lower the working ratio compared to the volumetric ratio, the faster the pump will stroke; the higher the working ratio, the slower the stroke rate.

As the working ratio becomes higher and higher in comparison to the volumetric ratio (that is, as the inlet pressure, determined by the height of the fall, gets lower; or as the output pressure, determined by the total lift, gets higher) the pump will stroke more and more slowly until it finally stops. The point at which the pump stops, known as the "stall ratio," is normally between 80% and 95% of the volumetric ratio.

When the pump is operated at a working ratio not too near the stall ratio, performance (defined as strokes per minute) improves, and thus more water is delivered. The working ratio can be closer to the pump ratio for a given delivery rate when using high inlet pressures, since the pump is inherently more efficient at these higher pressures. The High Lifter will restart itself automatically after any interruption of inlet water.

#### FLOW CONSIDERATIONS

The flow predictions shown on the charts in Appendix I assume an adequate supply of water from the source. With a 4.5:1 pump, you need four and a half gallons of source water for each gallon that is pumped. For example, to pump 500 gallons per day, you need 2250 gallons per day from the source, or one and a half gallons per minute.



If the flow is one gallon per minute, the performance will be a maximum of four strokes per minute, assuming sufficient fall for the given lift. Delivery will thus be a *maximum* of 300 gallons per day for a 4.5:1 pump and 150 gallons per day for a 9:1 pump, regardless of the lift and fall.

In other words, if the flow from the source is not adequate, the amount of water delivered will be less than predicted on the performance curves. The minimum flow necessary for pump operation is about one quart per minute. Piping is another consideration. On long runs of inlet piping (over 1000 feet), friction can increase the working ratio and therefore reduce delivery. Friction can be cut down and delivery improved by using a slightly larger diameter pipe. Friction loss in the delivery line is less significant.

#### *Note on water usage*

The highest average household use of water in the world is that of Sacramento, California, where water use is 275 gallons per day. Many households are content with 50 gallons per day.

With proper mulch and irrigation, a 100-square-foot vegetable garden can be grown with as little as 10 gallons per day. A large plant, such as a mature fruit tree, can use 10 gallons per day in the driest part of the season.

#### INSTALLING THE HIGH LIFTER

To install the High Lifter, connect the water source to the pump and the pump to the lift point with any available piping material. Flexible polyethylene tubing is usually the most convenient

A filter, which is supplied with each pump, must always be used. A hose, also supplied with the pump, should be placed between the filter and the pump.

A shut-off valve is installed on the output side of the pump. Gauges for inlet and output pressure are also supplied with the High Lifter.

It may take a day or so until the seals in the pump wear in and the High Lifter begins to deliver the rated amount of water. High-pressure leakage and leakage out the drain holes, located under the main cylinder, will also decrease somewhat during this time.

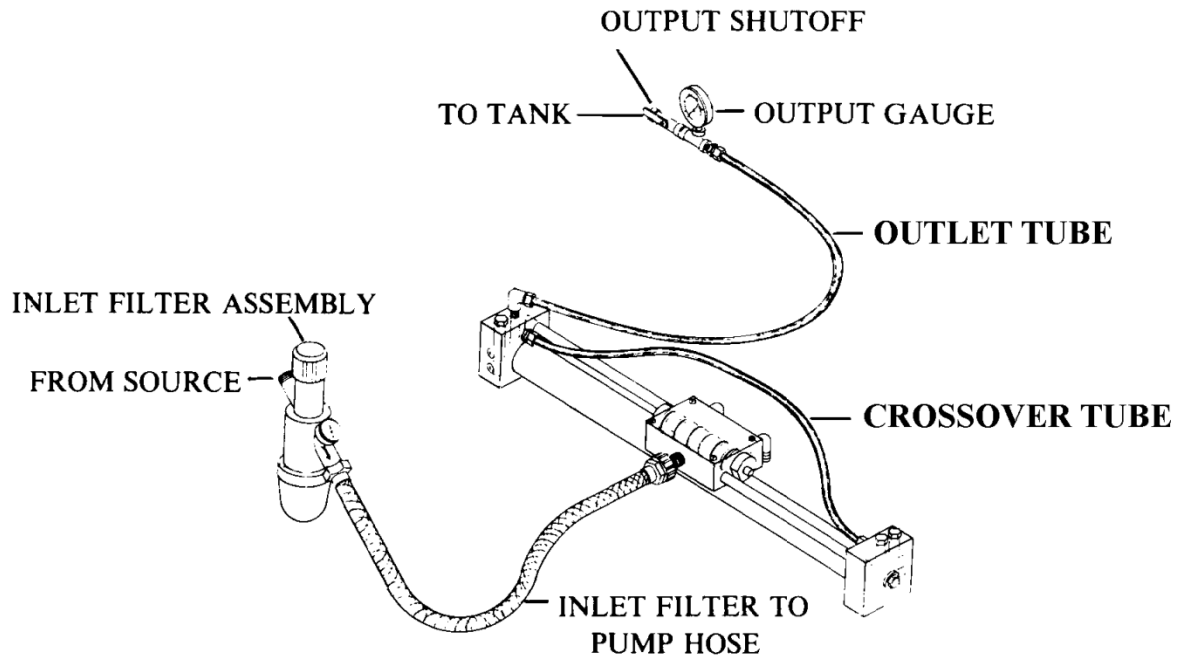

Figure 4. Filter and Hoses

#### THE WATER SOURCE AND COLLECTION POINT

The water source will usually be a spring or a running brook or creek. In some cases, a shallow well located on a hill can be used with a siphon arrangement (see below), but surface water is preferable. A spring may have to be developed to obtain adequate water for desired deliveries. *An inlet strainer at the source is always recommended.*

If the source is a spring, the best collection point is a spring box that strains the water through sand and gravel. A pipe is inserted into the box. The pipe inlet should be covered with a strainer.

A similar arrangement can be used to collect water from a creek.

Alternatively, the collection point can be a natural quiet pool or a pool created by damming the creekbed with rocks or other materials.

If the water at the collection point moves slowly, as in a spring box, particles will settle out and the filter will need less attention.

Low summer flows are often an important consideration when determining the best collection site. However, the height of the collection site below the use level (the net lift) is also important.

If the flow is very low, the High Lifter will operate intermittently, first pumping steadily for a stroke or two, and then stopping until the pressure builds again. With low flows, air can be introduced into the inlet pipeline, blocking or partially blocking it and sometimes stopping the pump. (See below)

## THE PUMP SITE

The pump itself can be situated at any convenient location. It will usually be placed at a stream bed or gully since these are at the lowest elevation.

The High Lifter can be left out in the open, but it must be protected from freezing. If freezing is a problem, it is best to place the pump below the frost level and cover it. Covering the pump also protects it from full sunlight, which helps prevent algae buildup.

If the pump is to be used for other applications during the year, it can be disconnected and moved to another set of pipelines.

Unlike gas pumps, the High Lifter needs no tank at the water source.

The portion of the water that is not pumped uphill can be returned to the stream bed or piped to other areas.

## THE FILTER

Inlet water *must be filtered* to protect the High Lifter from abrasive sand and dirt. A filter is supplied with every new pump. A dirty filter can cause dramatic drops in inlet pressure. The filter should be cleaned whenever this occurs. This procedure is described in the "Maintenance and Troubleshooting" section of this manual. Always disconnect the pump before cleaning the filter.

## PIPING

The High Lifter can be installed with any type of pipe or tubing that is strong enough to withstand the pressure. (This consideration is more important for the output line than the inlet line.) Flexible polyethylene tubing is usually used.

In most cases, the output or delivery line can be half-inch diameter for runs up to 2000 feet. The inlet or drive line can be one inch diameter for runs up to about 1000 feet. Smaller piping can be used, but loss of pressure due to friction will be greater.

Since the energy extracted from the water in the inlet line operates the pump, any kinks or obstructions in this line will slow or stop the pump.

## AIR BUBBLES

Air bubbles in the inlet lines are the system's most common problem. If the inlet line has high spots with trapped air, the pump may slow down or even stop. However, air bubbles won't damage the High Lifter.

To prevent air pockets, avoid high spots in the inlet line. The inlet line should travel downhill as consistently as possible, especially near the top.

If air bubbles do develop, they may dissolve into the water on their own.

Alternatively, the bubbles can be flushed out or vented by lifting the low spots, or by poking a hole in the pipe with drip irrigation tools. The hole should then be plugged with a plug made for this purpose.

## SIPHONING

Siphon systems tend to be finicky and prone to problems, mainly due to air leakage or water levels that go so low that the siphon is "broken." If a siphon is necessary, it is best to put it between the water source and a reservoir outside the source. The water is then drawn from the reservoir *above* the bottom of the siphon pipe. This prevents the pump from reducing the water level in the source enough to break the siphon.

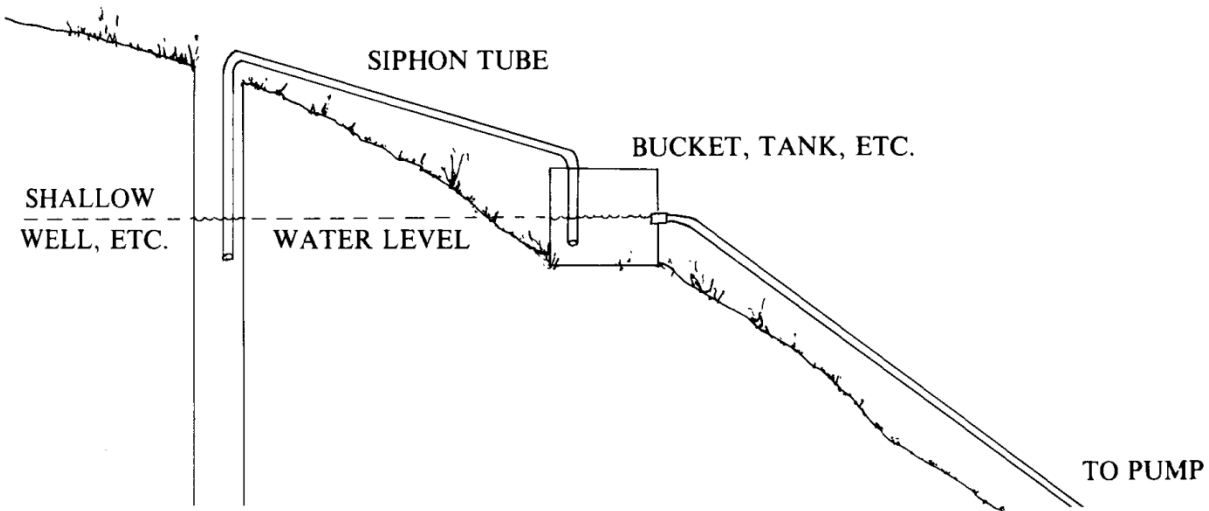

Figure 5. Preferred Method of Siphoning

## MAINTENANCE AND TROUBLE-SHOOTING

The High Lifter is designed to be maintained by the user. All its parts are completely accessible, and no special tools are needed to work on it. The most frequent maintenance task is cleaning the filter; the duration between cleanings depends on the quality of the source water.

The wearing parts of the pump will last one to three years or more, depending on water quality and other conditions of use. Though low pressure and low speed will somewhat extend the life of the seals, they will wear out after millions of strokes.

Replacements, which are easily installed, are available at [www.humboldtsolarwaterpump.com](http://www.humboldtsolarwaterpump.com). With normal maintenance, the High Lifter itself will last more than ten years.

Allowing abrasives to get into the pump is the chief cause of premature wear. To prevent the introduction of abrasives, clean all parts thoroughly prior to reassembly and *always filter the water properly*.

If your lift or delivery requirements change, you can convert the High Lifter's volumetric ratio. The conversion is accomplished by replacing a few parts; again, no special tools are needed.

## CLEANING THE FILTER

Unless the water is unusually dirty and fast at the collection point, the filter shouldn't need cleaning more than once a month. If your collection system settles out or strains out the debris in the water, the filter can be cleaned less often. Dramatic drops in inlet pressure may be caused by a dirty filter. Before cleaning the filter, close the valve and disconnect the pump. Then unscrew the filter element cover, remove the strainer disks, and wash between them. You should also flush out the inlet line to remove any debris at this time. Then replace the strainer disks, making sure the spring is in place, and replace the cover snugly but not too tight. Reconnect the pump.

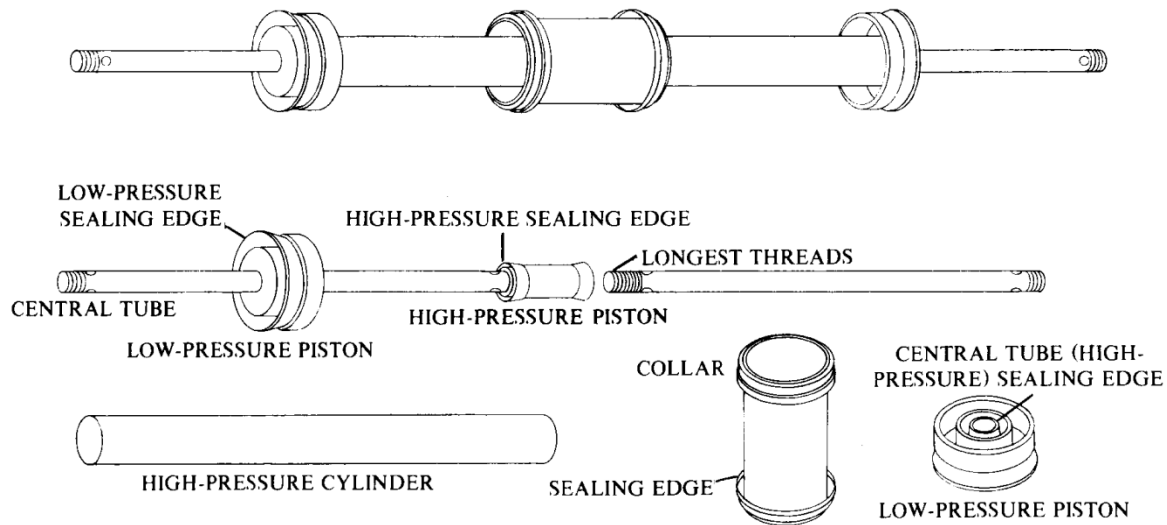

Figure 6. Internal Assembly and Components

## DISASSEMBLY

To disassemble the pump, first loosen and remove one end nut and washer. Remove the head by gently twisting and pulling. If necessary, you can pull the central tube from the other end an inch or two in order to get the head completely off. Remove the second end nut and washer from the tube and pull out the insides of the pump from the first end.

Grasp a low-pressure piston in each hand. Twist and pull them apart to get access to the high-pressure piston inside the high-pressure cylinder.

## ASSEMBLY

Assembly is the reverse process. Wash off any grit or dirt from the internal parts. As you insert the pistons into their cylinders, *care not to damage their sealing edges*. Make sure to push the pistons all the way home on the high-pressure cylinder. A gently twisting back and forth motion while pushing helps.

Do not over-tighten the end nuts. A wrench on one end and your fingers on the other is sufficient. When the pump is operating, the tube should be snug against the head. If it moves, tighten the end nuts just until it stops moving. The seals are made from a somewhat moldable material that can be manipulated if necessary. For instance, if the low-pressure piston seals get dented while being handled, you can restore them to their original form by gently massaging them into place with the back of your thumb nail.

The same technique also usually cures "whistling" or excessively leaking collar seals. The small central tube seals located in the center of the low-pressure piston are easily damaged when assembling the pump.

As you reassemble the pump, take care to center the collar in the barrel. If it is not centered, the collar won't be able to control the valve. Water will squirt out one or both drain holes on the bottom of the barrel and the pump may not work. To correct the problem, give the pump an initiating valve shift by pressing one of the buttons on the end of the valve. Then try the other button. The first complete stroke will push the collar to its correct place and the pump will begin to behave normally.

#### THE CONTROL VALVE

To disassemble the valve, remove the screws from the caps on the ends of the valve. Then remove the spool. Use a dental pick or an ice pick to remove the o-rings. When reassembling the valve, tighten the cap screws lightly. The valve is secured to the pump barrel with glue and metal straps. This is to ensure that the passages in the valve are aligned with the holes in the barrel. It is not normally necessary to remove this valve from the barrel for any maintenance procedure.

#### HIGH-PRESSURE PISTON AND RATIO CHANGEOVER

To change the high-pressure piston, unscrew the piston from the central tubes, taking care not to scratch them. If necessary, use nails in the holes at the ends of the tubes as a kind of wrench to give you enough leverage to screw the tubes off the piston. Do not use a pipe wrench or pliers on the tube.

When you install the new piston, start it on the threads of the central tube carefully so as not to cross-thread it. Be sure to screw in the end of the tube with the longer threading. Tighten until all the threads of the tube have disappeared into the piston. Use a nail or two nails to snug the tubes in the piston. Be careful not to over-tighten them, which could strip the threads in the piston.

To change the ratio of the High Lifter, replace the high-pressure piston, the high-pressure cylinder, and the low-pressure pistons with pistons and cylinders designed for the desired ratio. Changeover kits (HWSP # 10-1115 or # 10-1124) are available.

## TROUBLE-SHOOTING PROCEDURES

The trouble-shooting flow chart in Appendix II will help you find and fix any problems with your High Lifter pump or with the entire pumping system. This section outlines the main problem areas: the inlet line, the low-pressure system, the high-pressure system, and the pilot system and valve.

First, read the inlet pressure and output pressure gauges. If the inlet pressure is too low for the amount of fall in the system, the problem is probably at the collection point, in the inlet line, or in the filter. *The vast majority of problems are of this nature.*

If the output pressure is too high, the problem is probably that the output line is obstructed. If the output pressure is too low, read the section on the high-pressure system below.

The relationship between the high-pressure output and the low-pressure inlet (the working ratio) is an important diagnostic tool. It allows you to determine if it is the system or the pump that is at fault. For example, a 4.5:1 pump cannot pump at a working ratio of 6:1.

If the working ratio is reasonable, the problem is probably in the pump itself.

There are three systems to analyze:

- the low-pressure system
- the high-pressure system
- the pilot system

Low-pressure problems can be analyzed by observing how much water leaks out the drain holes at the center bottom of the pump barrel. If there is a substantial amount of water and hissing out the drain holes, examine the low-pressure pistons, collar, and main cylinder.

High-pressure (output) problems can be analyzed by performing a stall test, described in the "Leakage Tests" section below. Be sure to stall the pump in both directions of piston travel. If the high-pressure output line is closed and the pistons continue to travel with any speed, examine the high-pressure piston sealing surfaces, the high-pressure cylinder, the central tube, and the central tube seals located in the center of the low-pressure pistons.

If water is hissing out the drain holes, the pilot system may be affected.

Problems in the pilot system may also be due to malfunctions in the main valve.

If the spool is not shifting or is shifting very slowly, first examine the valve discharge fittings. Water should be exhausting from only one discharge fitting at a time. If both fittings are exhausting, the valve spool and/or its o-rings may need attention.

Since the spool is controlled by the collar inside the pump, a non-shifting spool could also be caused by a mislocated or damaged collar or a plugged pilot hole (most likely the center hole).

## LEAKAGE TESTS

After a while, the seals in the High Lifter will wear and begin to leak. Low-pressure leakage is permissible until water hisses out of both drain holes. This situation can cause erratic or slow valve spool movement, since the pilot water must also exhaust out these holes at each spool shift.

High-pressure leakage can cause "quick strokes" and dramatic drops in output pressure and loss of delivered water. High-pressure leakage can be detected with a *stall test*. This test is conducted by simply shutting off the valve on the discharge (output) line. The High Lifter will pump as high a pressure as it can with your available inlet pressure and then stall. Be sure to repeat the test with the pistons moving in the other direction (with the water coming out the other exhaust port).

The speed at which the pistons travel in this condition of stall is an indication of high-pressure leakage. A "hard" stall, or one where the pistons barely move and exhaust water barely flows, means that the entire high-pressure system is tight up to the shut-off valve.

A "soft" stall — the pistons travelling slowly and water dribbling from one exhaust port — means there is high-pressure leakage somewhere. Usually, high-pressure leakage is at the seals. Sometimes, it occurs at the check valves in the heads.

A certain amount of leakage is permissible. From 20 to 40 seconds between shifts (half a stroke) is usually acceptable.

If the amount of leakage is unacceptable for your application, you may want to replace all the moving parts:

- Low-Pressure Piston, qty 2
- High-Pressure Piston, qty 1
- Collar, qty 1

These pistons are available as a rebuild kit, either HSWP #10-1118 (4.5:1) or HSWP #10-1124 (9:1). The Collar is available as HSWP #10-1359. It is not included in the rebuild kit as it usually doesn't need replacing as often as the pistons do.

If the pistons are good, high-pressure leakage may be occurring at the check valves in the heads. They can be inspected visually while they are operating for any obvious malfunctions, such as being stuck due to debris in that area. If it's a very small leak, you can often see the leak area by shining a flashlight up under the head so it shines on the check valve area. Look with a magnifying glass at how the check valve ball seats on the check valve o-ring. A slight leak will show as a sliver of light emerging between the o-ring and ball.

To determine the exact location of the leakage, you can isolate the leaking part by switching parts end for end to see whether the leak, as seen in a stall test, changes sides. First, disassemble the pump and pull out its insides. Then reassemble it, with the insides rotated end for end, and repeat the stall test. If the leak does not change sides it is probably in the heads (since they were not switched). This would be either a check valve problem or, rarely, a leak past the central tube o-ring.



If the leak does change sides, remove the central tube and high-pressure piston and rotate it end for end, keeping the low-pressure pistons in the same relative position. Reassemble the pump and repeat the stall test. If the leak does not change sides, it is a worn low-pressure piston. If it does change sides, it is the high-pressure piston.

In an emergency, if replacement parts are not immediately available, you can try to recondition a worn seal by scraping it lightly with a knife or very sharp, very fine sandpaper. Then reshape the seal by flaring it gently outwards (or inwards in the case of a central tube seal) with the back of your fingernail or some other smooth object.

#### COLLAR OPERATION AND PILOT TESTS

The opening and closing of the valve is controlled by the collar as "pilot" water flows through it. If this signal is interfered with, the valve will not shift.

The pilot pressure (or lack of it) at the spool ends can be felt by using your fingertips on the buttons at the ends of the valve. If the pistons are at the end of their stroke and the valve doesn't shift and there is no pressure at the appropriate end of the spool, it means either that the collar has not moved far enough to direct the pilot water to the valve, that there is excessive collar or low-pressure leakage, or that there is some other malfunction such as a plugged up pilot passage.

The water at the end of the spool opposite the pressurized end must exit out the drain holes in order for the spool to shift. This sudden lack of pressure or "pilot release" can also be felt at the buttons.

#### VALVE OPERATION TESTS

If there is pilot pressure and the valve won't shift, a spool may be sticking, dirt may be in the valve, or spool o-ring may be damaged. It is possible, though very unlikely, that if there seems to be some obstruction in the pilot system, the matching holes in the main barrel and the bottom of the valve are misaligned due to the movement of the valve on the barrel. This could have been caused by a hard knock to the valve or if the nuts holding the valve on the barrel were loosened. These nuts must not be over-tightened, as they can squash the barrel out of round.

The holes in the barrel can be seen through the valve body if you look carefully. The alignment can also be checked by carefully inserting a bent wire about one sixteenth inch in diameter. By poking this wire up from the inside of the barrel into the valve through one of the top three holes you can determine if the matching holes are misaligned or plugged.

With enough use, the valve parts will wear and begin to leak, causing water to come out of both exhaust ports simultaneously. A small amount of leakage is permissible, but if water is leaking from the pilot (end) section of the valve, examine the o-rings. They need not be snug on the spool, but if they appear worn to the point of being flat on the inside, they may be allowing water to pass around them, causing leakage. If the end o-rings are

leaking, they can stop the valve from shifting. You can determine if this is the case by plugging one of the exhaust ports with your finger to see whether the valve shifts.

O-rings (especially end o-rings) that fit too tight around the spool can also cause leakage. In order to seal, the o-rings must travel slightly sideways in their grooves so that they make contact with the face of the groove. If the o-rings are so tight that they stick on the spool, water can travel around them and through the groove into the next chamber.

This situation is most likely to arise after the o-rings have been replaced. To determine if an o-ring is sticking, push one of the valve buttons slightly and see whether the o-ring is loose enough to move and seal, causing the valve to shift. If it does not, you can correct the problem by replacing the o-rings or the spool to get a proper fit. Spool o-rings are available as HSWP # 10-1311; kits containing a spool and o-rings are available as HSWP # 10-1127.

#### APPENDIX I. PERFORMANCE CURVES

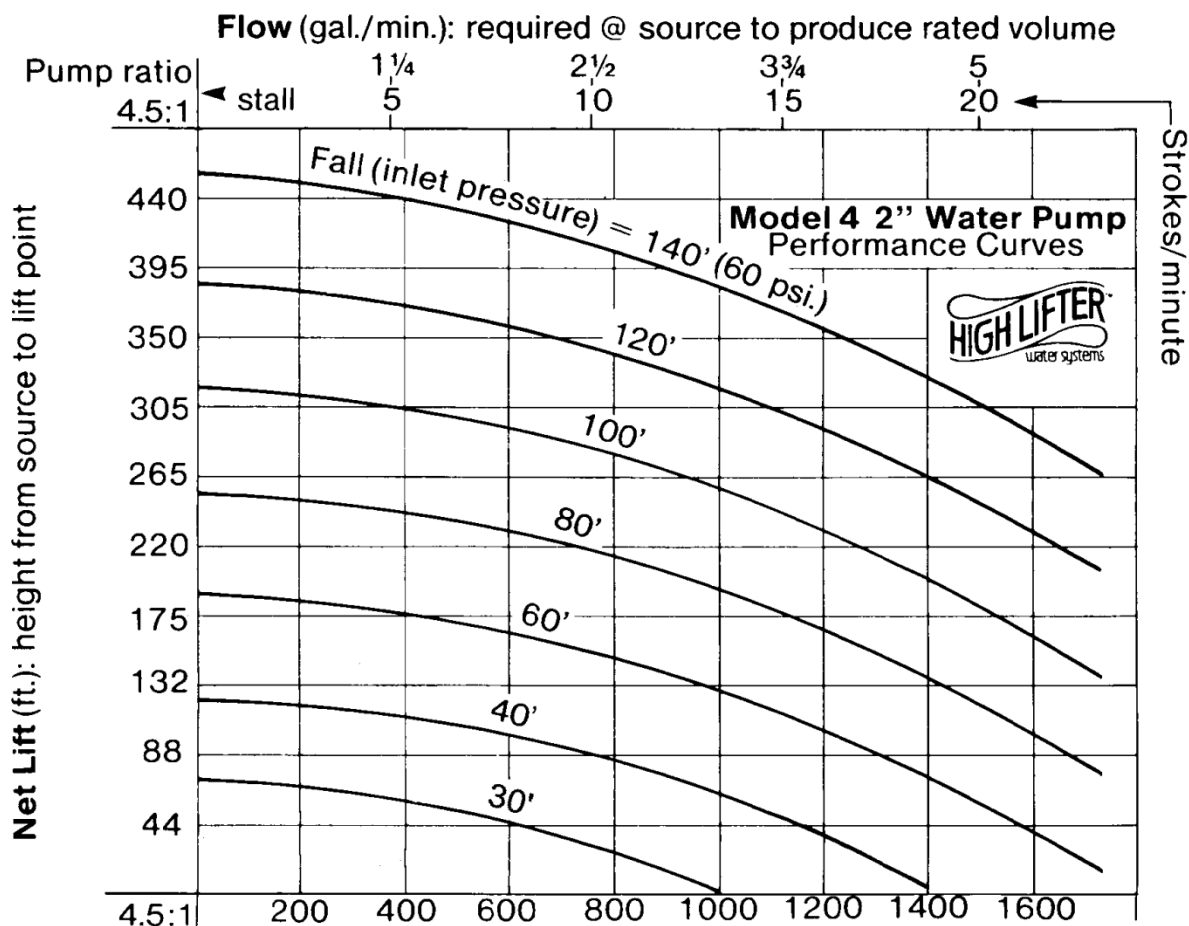

1 psi = 2.3'      **Delivery (gal./day):** assuming adequate water @ source

Figure 7. Performance Chart for the 4.5:1 Volumetric Ratio Pump

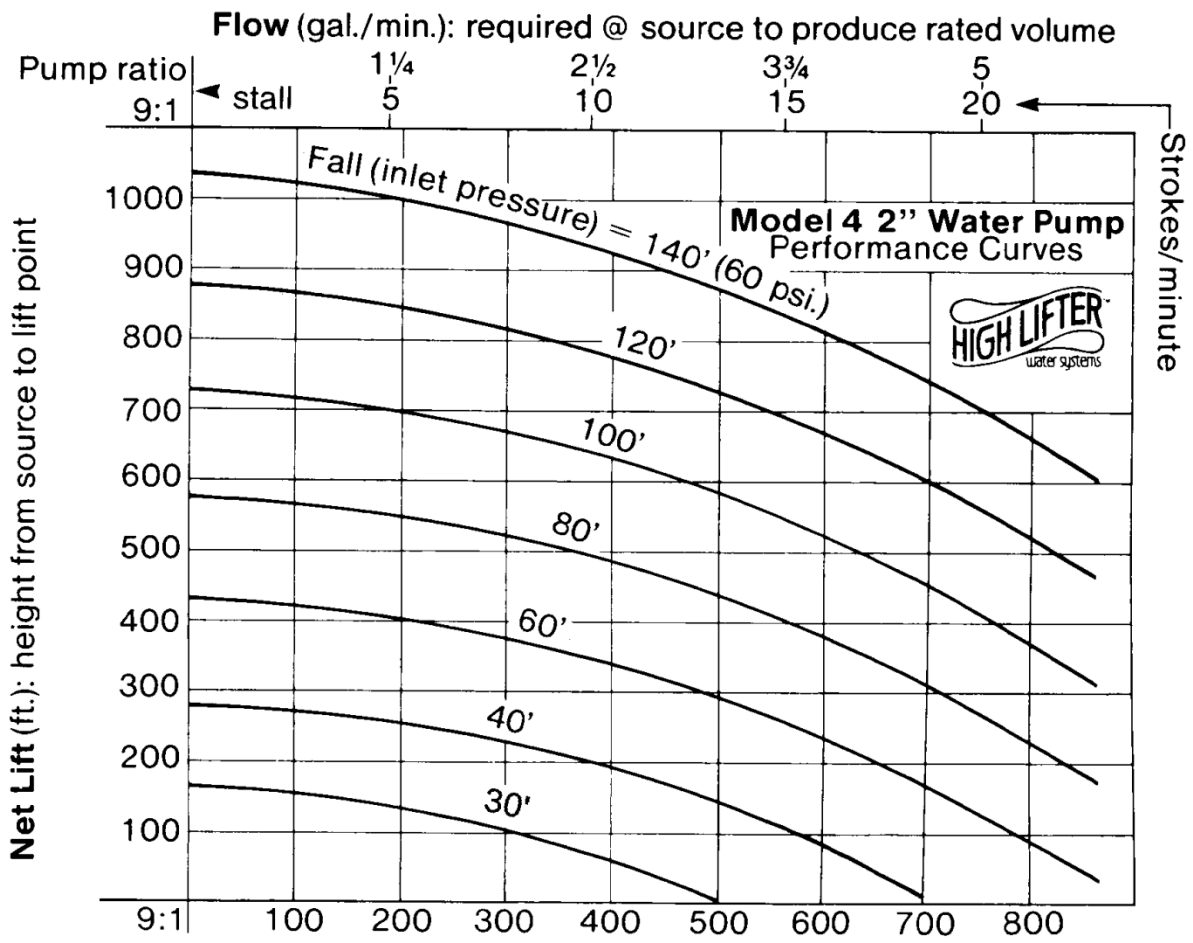

1 psi = 2.3'      **Delivery** (gal./day): assuming adequate water @ source

Figure 8. Performance Chart for the 9:1 Volumetric Ratio Pump

## APPENDIX II. TROUBLE-SHOOTING FLOW CHART

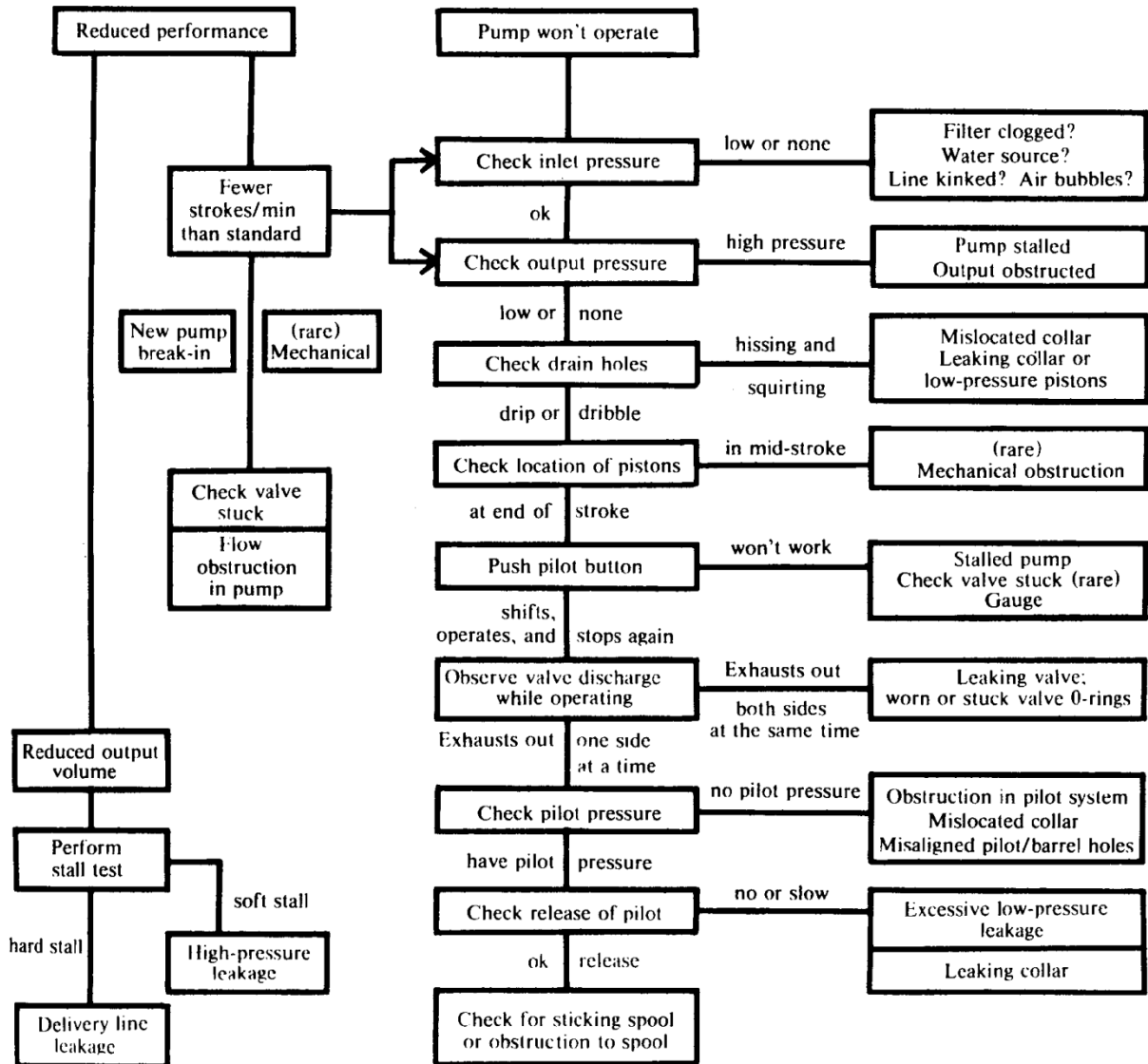

Figure 9. Troubleshooting Flow Chart

APPENDIX III. Parts Breakdown Illustrations

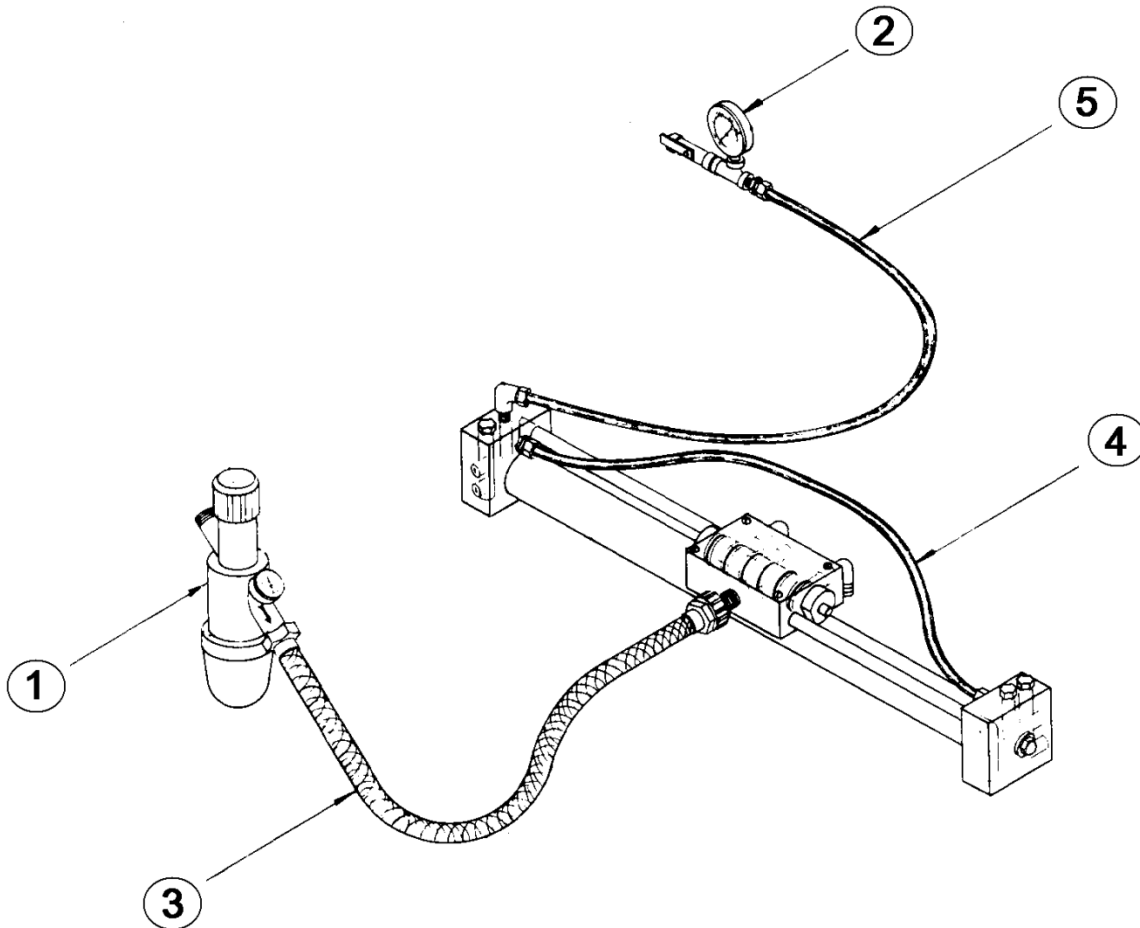

Figure 10. Hose, Tube, and Gauge Parts

Item #	Part #	Description	Qty
1	1393	Inlet Filter Assembly with Gauge	1
2	1398	Output Gauge Assembly (0-300 psi, 4.5:1 pumps)	1
2	1400	Output Gauge Assembly (0-600 psi, 9:1 pumps)	1
3	1401	Inlet Hose	1
4	1405	Crossover Tube	1
5	1409	Outlet Tube	1

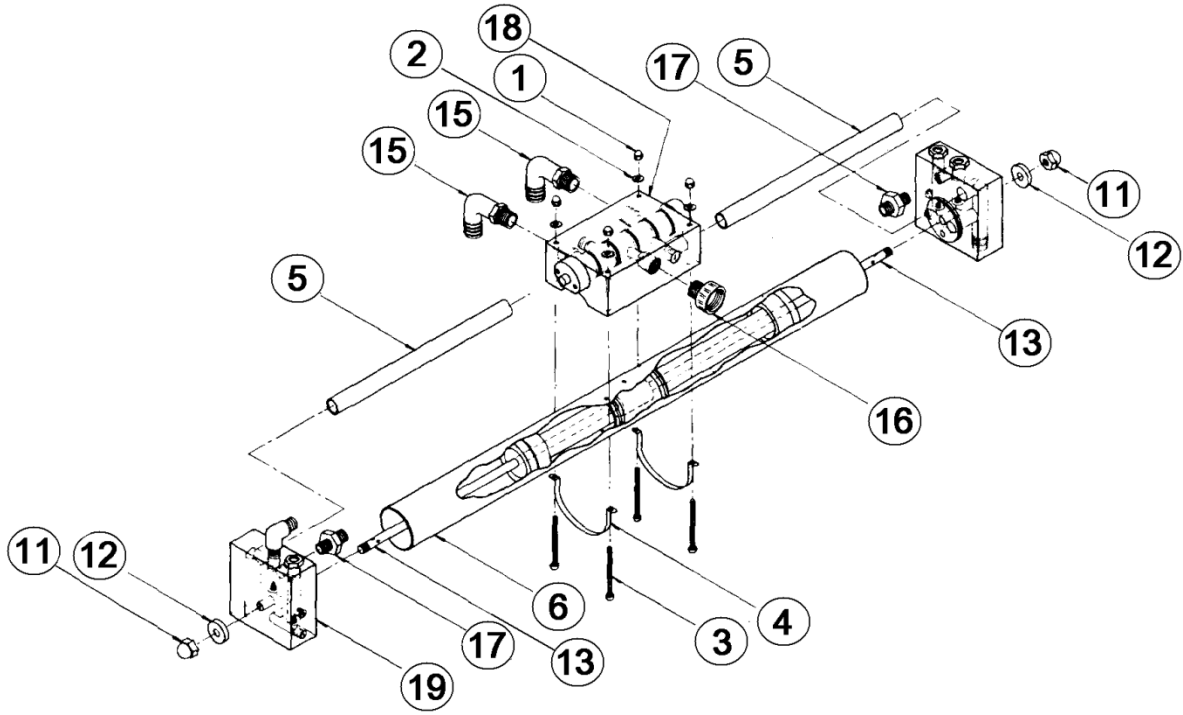

Figure 11. Overall View

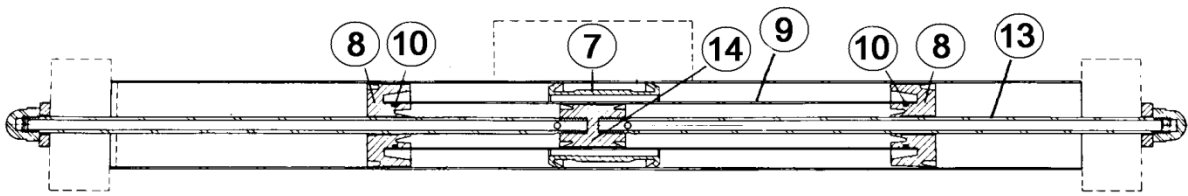
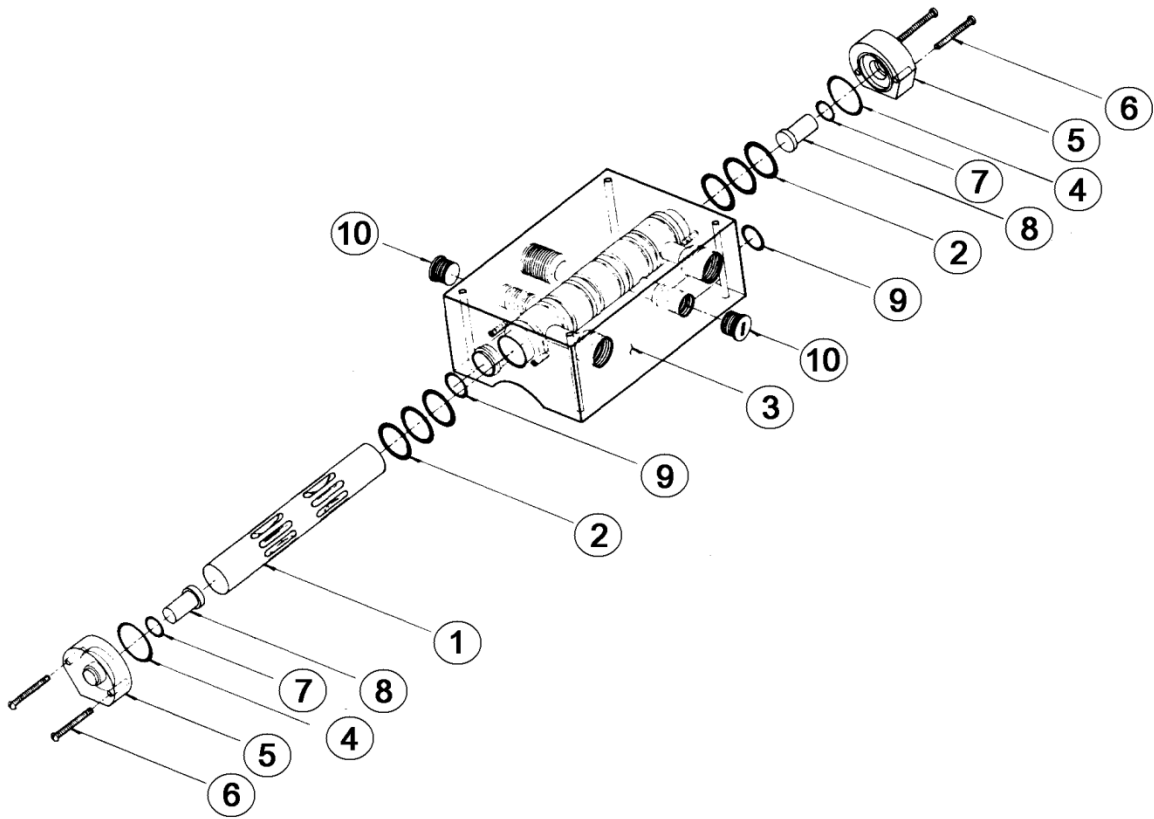

Figure 12. Cylinder Cutaway View

Item #	Part #	Description	Qty
1	1319	Strap Nut	4
2	1321	Strap Washer	4
3	1323	Strap Screw	4
4	1325	Strap	2
5	1349	Comm Tube	2
6	1357	Barrel	1
7	1359	Collar	1
8	1361	Low Pressure Piston 4.5:1	2
8	1363	Low Pressure Piston 9:1	2
9	1365	High Pressure Cylinder 4.5:1	1
9	1367	High Pressure Cylinder 9:1	1
10	1369	Low Pressure Piston o-ring 4.5:1	2
10	1371	Low Pressure Piston o-ring 9:1	2
11	1373	End Nut	2
12	1375	End Nut Washer	2
13	1377	Central Tube	2
14	1379	High Pressure Piston 4:5:1	1
14	1381	High Pressure Piston 9:1	1
15	1383	Valve Discharge Fitting	2
16	1385	Valve Inlet Fitting	1
17	1411	Straight Fitting	2
18	1329	Valve (only sold as an assembly)	1
19	1351	Head (only sold as as assembly)	2

Figure 13. Valve Assembly



Item	Part #	Description	Qty
1	1317	Spool	1
2	1327	Valve O-ring	6
3	1329	Valve(only sold as an assembly)	1
4	1331	Cap O-ring	2
5	1333	Valve Cap	2
6	1335	Cap Screws	4
7	1337	Button O-ring	2
8	1339	Button	2
9	1347	Communication Tube O-ring	4
10	1387	Valve Plug Slotted 1/4"	2



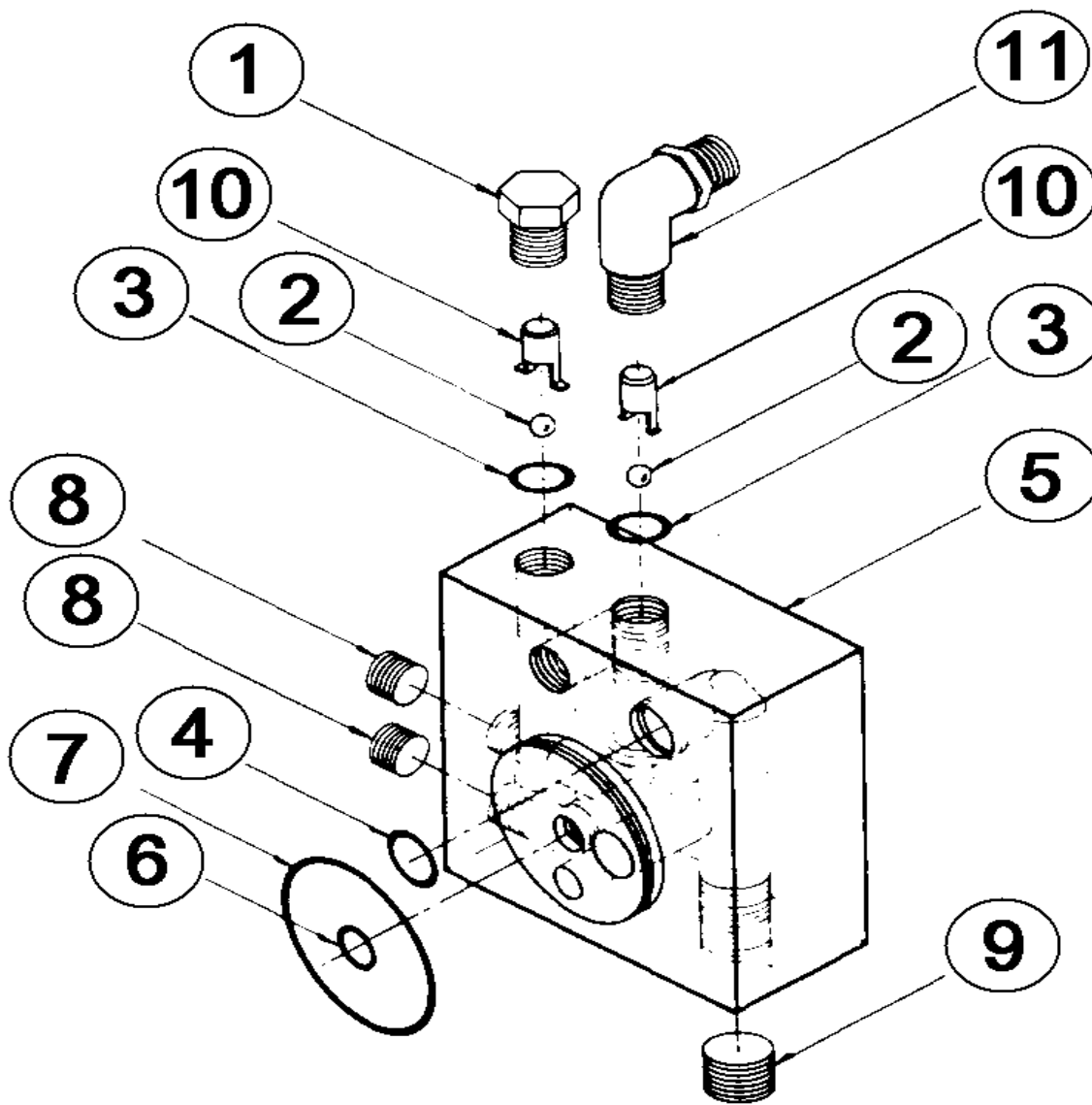

Figure 14. Head Assembly

Item #	Part #	Description	Qty
1	1341	Plug	2
2	1343	Check Valve Ball	2
3	1345	Check Valve O-ring	2
4	1347	Comm Tube O-ring	1
5	1351	Head (only sold as an assembly)	1
6	1353	Central Tube O-ring	1
7	1355	Head O-ring	1
8	1389	Head Plug Slotted 1/8"	2
9	1391	Head Plug Flush 3/8"	1
10	1413	Check Valve Insert	2
11	1407	EII Fitting	1

APPENDIX IV. Specification Data

Positive displacement, piston type, water powered water pump.

Cylinder material:	stainless steel
Valve and head material:	acrylic
Filter:	supplied with pump
Diameter of main cylinder:	2"
Length:	26"
Weight:	5½ lbs
Inlet connection:	¾" MNPT
Outlet connection:	½" MNPT

Note: pump ratios can be changed by using a changeover kit.

Model	4.5:1	9:1
Pump Volumetric Ratio	4.5:1	9:1
Maximum Output per Day	1500 gal	750 gal
Maximum Lift	450ft.	950ft
Maximum inlet pressure	60 psi.	60 psi.
Minimum inlet pressure	13 psi.	13 psi.
Shipping weight	10 lbs.	10 lbs.
Shipping dimensions	6"x 6"x 28"	same



High Lifter Owner's Manual v 2p May 2015